



A U.S. BLOCK WINDOWS COMPANY

VR 3000

Retro Fit Instructions

(For use when original window is fully removed)

Tools Required

Tape Measure
Level
1/4" x 1-1/2" Lag Screws
7/16" Socket Driver
Silicone Sealant
Vinyl or Sheet Metal Snips

Electric Drill
1/4" Drill Bit
Caulking Gun
Shim Material
Small Rubber or Plastic Tip Hammer
Level

Note: This type of frame should only be used when the entire existing window has been removed and the exterior façade opening is roughly flush with the framed opening.

Installation Options

This window can be measured and installed in two different ways. It can be made to butt against the interior wall covering or casing or it can bypass the return or casing. In either case it is necessary to determine this prior to ordering the unit, as the measurements will be different. Please refer to the drawings below.

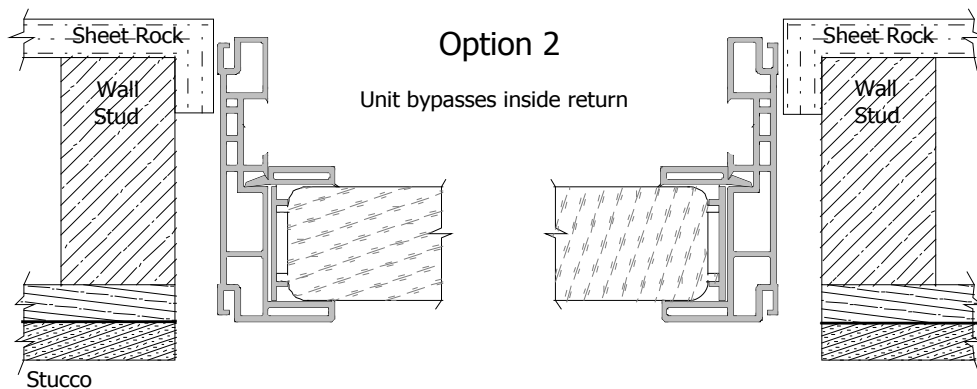
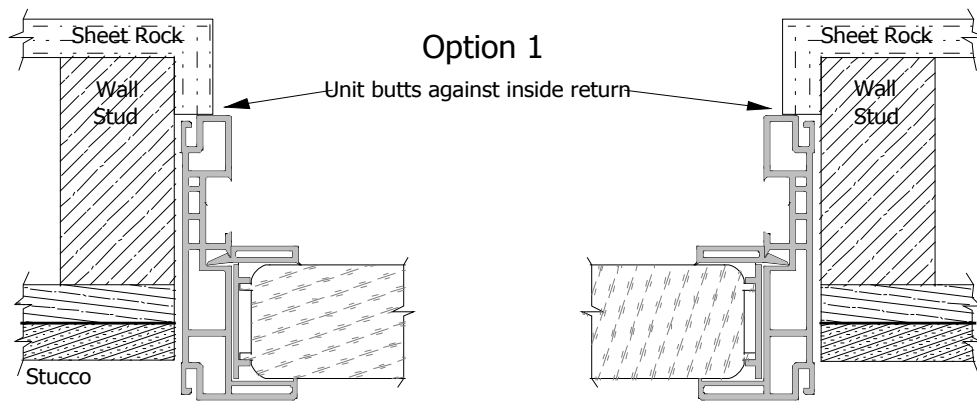

Installation

Regardless of which installation option you are using, installations procedures will be the same.

1. Test fit the window in the opening. If there are no obstructions or issues with the fit of the window, you can pre-drill the installation holes in the frame.
2. 1/4" holes should be drilled in the screw track approximately 6" from the end of each frame member. Then drill a hole every 12" between those. (Illustrations 1 and 2)

Illustration 1

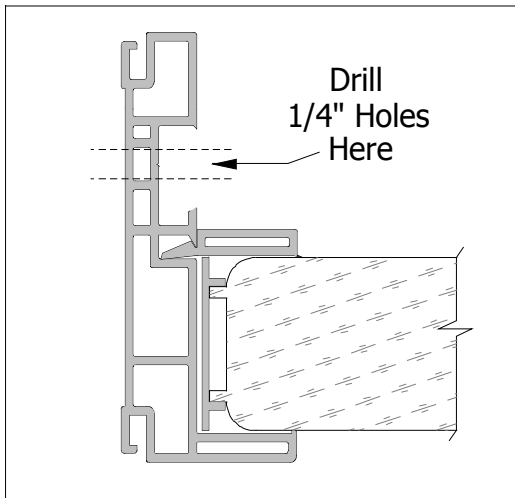
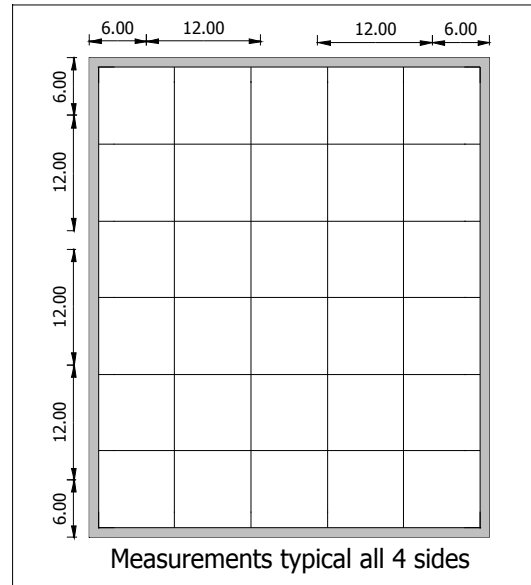
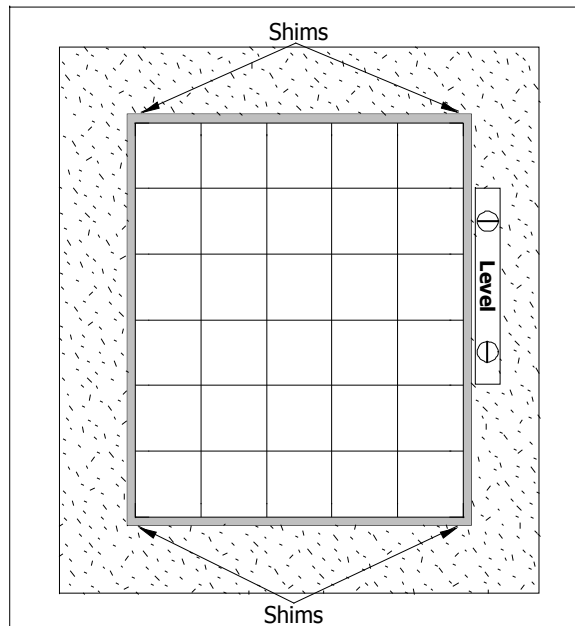

Illustration 2



3. When all the holes are drilled, slide the window into the opening from the outside to the desired depth.
4. Insert shims at the top and bottom corners to center the window in the opening. (Illustration 3)
5. Using the level on the jamb, adjust the shims until the window is as close to plumb as possible.

Illustration 3



- When the unit is satisfactorily positioned and plumbed, install a 1/4" x 1-1/2" Lag Screw at the top and bottom of each jamb. Before tightening the screws, shims should be placed between the wall framing and window frame at the screw location to prevent bowing of the frame and to provide strength. Refer to Illustration 4 for screw and shim installation. (Longer screws may be necessary for penetration into the wall framing. At least 3/4" penetration is recommended)

DO NOT OVER TIGHTEN THE SCREWS!

The screws should be tightened until they are snug against the window frame. Over tightening can cause bowing of the frame and possible seal failure.

Illustration 4

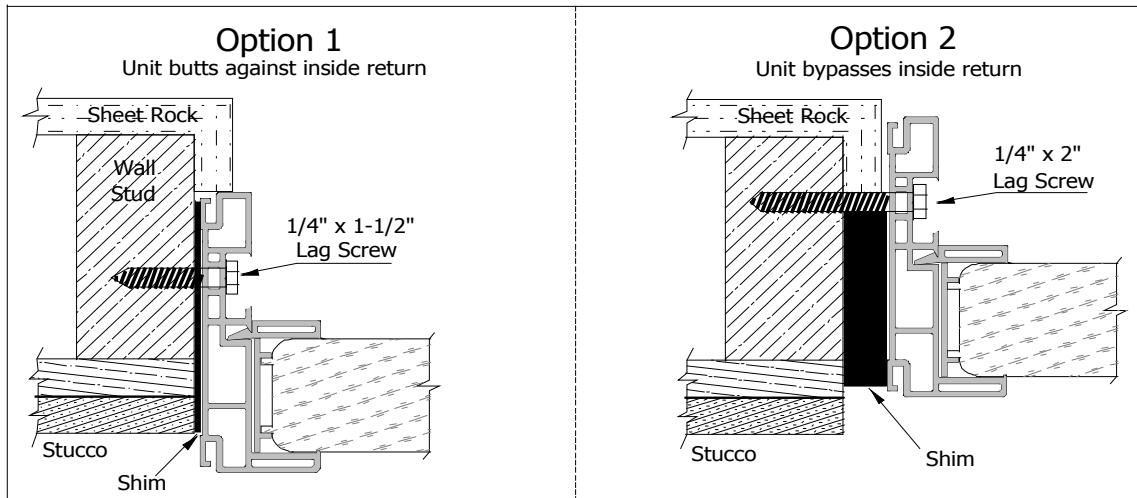

- When all 8 corner fasteners are installed, recheck the unit for plumb and placement. If all is satisfactory, repeat step 6 for the remaining fasteners.
- If desired, foam insulation can be applied to any remaining voids between the window frame and the wall opening. **Foam insulation must be the non-expanding type.**
- A vinyl cover is provided to cover the screw track. It will need to be cut approximately 1/16" longer than the track with snips. Lay the cover in the track and tap it lightly with a rubber or plastic tipped hammer. It should snap into place. (Illustration 5)

Illustration 5

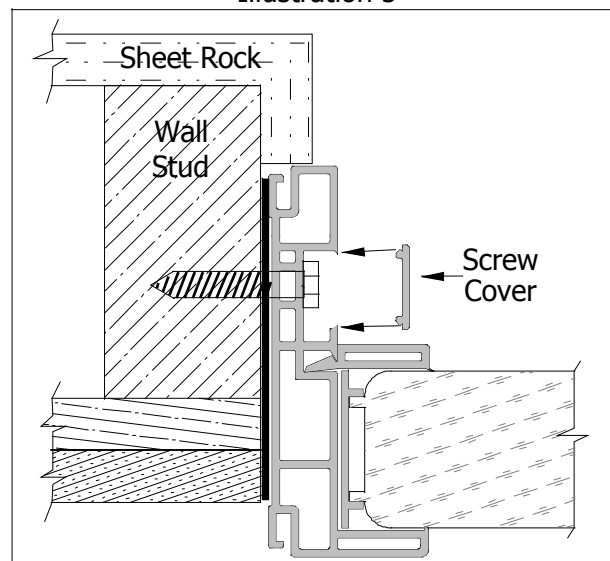

10. A high-grade silicone sealant should be used inside and out to seal the gaps between the window frame and the opening. If gaps exceed $\frac{1}{4}$ " in width, it may be necessary to cover them with a decorative trim or brick mold. These items should be sealed with silicone as well. (Illustration 6)

Illustration 6

